

**Power
max**
Inverter
Series
GENERATOR

2200W
DIGITAL INVERTER GENERATOR

4.5L
FUEL
TANK

UP TO
8 hrs
@
50%
LOAD

1x
230V
AC POWER
OUTLET

iX2300



iX2300

OPERATING MANUAL

Contents

Introduction.....	3
Environmental protection.....	3
Specifications.....	3
Scope of product.....	3
Description of symbols.....	3
Safety instructions for power tools.....	4
Know your product.....	8
Unpacking.....	8
Control panel functions.....	9
Before use.....	12
Adding fuel.....	12
Adding / checking engine oil.....	13
Grounding the generator.....	13
Standard atmospheric conditions.....	13
How to start engine.....	14
How to stop engine.....	15
How to attach electronic devices.....	15
Charging a 12V battery.....	16
AC parallel operation.....	17
Approximate wattage requirements.....	18
Maintenance.....	19
Storage and transportation.....	23
Troubleshooting.....	25
Wiring diagrams.....	26
Warranty.....	29

Introduction

Your new POWERMAX Generator will more than satisfy your expectations. It has been manufactured under stringent quality standards to meet superior performance criteria. You will find your new tool easy and safe to operate, and, with proper care, it will give you many years of dependable service.

Carefully read through this entire Instruction Manual before using your new POWERMAX Generator. Take special care to heed the cautions and warnings.

Your generator has many features that will make your job faster and easier. Safety, performance, and dependability have been given top priority in the development of this tool, making it easy to maintain and operate.

Environmental Protection

Recycle unwanted materials instead of disposing of them as waste. All tools, hoses and packaging should be sorted, taken to the local recycling centre and disposed of in an environmentally safe way.



Scope Of Product

This generator is an engine-driven, portable generator. It is designed to supply electrical power to operate tools, appliances, camping equipment, lighting, or serve as a backup power source during power outages.

Description Of Symbols

The rating plate on your tool may show symbols. These represent important information about the product or instructions on its use.



Wear hearing protection.
Wear eye protection.
Wear breathing protection.



Conforms to relevant standards for electromagnetic compatibility.

Specifications

AC Output	Rated AC Voltage	230V
	Rated Frequency	50Hz
	AC Current	8.7A
	Rated Output	2000W
	Maximum Output	2200W
DC Output	USB Outlet	5V DC 1.5A
	Cigarette Outlet	12V DC 8A
Engine	Displacement	98cc
	Engine Type	Single cylinder, 4 Stroke, OHV, Air Cooled
	Engine Oil Type	SAE 10W30
	Engine Oil Capacity	350ml
	Fuel Tank Capacity	4.5L

Safety Instructions for Power Tools

To use this tool properly, you must observe the safety regulations, the assembly instructions and the operating instructions to be found in this Manual. All persons who use and service the machine have to be acquainted with this Manual and must be informed about its potential hazards. Children and infirm people must not use this tool. Children should be supervised at all times if they are in the area in which the tool is being used. It is also imperative that you observe the accident prevention regulations in force in your area. The same applies for general rules of occupational health and safety.



WARNING:

When using power tools, basic safety precautions should always be taken to reduce the risk of fire, electric shock and personal injury. Also, please read and heed the advice given in the additional important safety instructions.

- 1. Keep the work area clean and tidy.** Cluttered work areas and benches invite accidents and injury.
- 2. Consider the environment in which you are working.** Do not use power tools in damp or wet locations. Keep the work area well lit. Do not expose power tools to rain. Do not use power tools in the presence of flammable liquids or gases.
- 3. Keep visitors away from the work area.** All visitors and onlookers, especially children and infirm persons, should be kept well away from where you are working. Do not let others in the vicinity make contact with the tool or extension cord.
- 4. Store tools safely.** When not in use, tools should be locked up out of reach.
- 5. Do not force the tool.** The tool will do the job better and safer working at the rate for which it was designed.
- 6. Use the correct tool for the job.** Do not force small tools or attachments to do the job best handled by a heavier duty tool. Never use a tool for a purpose for which it was not intended.

7. Dress correctly. Do not wear loose clothing or jewellery. They can be caught in moving parts. Rubber gloves and non-slip footwear are recommended when working outdoors. If you have long hair, wear a protective hair covering.

8. Use safety accessories. Safety glasses and earmuffs should always be worn. A face or dust mask is also required if the drilling operation creates dust.

9. Secure the work piece. Use clamps or a vice to hold the work piece. It is safer than using your hand and frees both hands to operate the tool.

10. Do not overreach. Keep your footing secure and balanced at all times.

11. Look after your tools. Keep tools sharp and clean for better and safer performance. Follow the instructions regarding lubrication and accessory changes. Inspect tool cords periodically and, if damaged, have them repaired by an authorised service facility. Inspect extension cords periodically and replace them if damaged. Keep tool handles dry, clean and free from oil and grease.

12. Remove adjusting keys and wrenches. Check to see that keys and adjusting wrenches are removed from the tool before switching on.

13. Stay alert. Watch what you are doing. Use common sense. Do not operate a tool when you are tired.

14. Check for damaged parts. Before using a tool, check that there are no damaged parts. If a part is slightly damaged, carefully determine if it will operate properly and perform its intended function. Check for alignment of moving parts, binding of moving parts, breakage of parts, proper mounting and any other conditions that may affect the operation of the tool. A part that is damaged should be properly repaired or replaced by an authorised service facility, unless otherwise indicated in this Instruction Manual.

15. Use only approved parts. When servicing, use only identical replacement parts. Use an authorised service facility to fit replacement parts.



WARNING:

The use of an accessory or attachment, other than those recommended in this Instruction Manual, may present a risk of personal injury.

Save these important safety instructions

Risk of electrocution and fire		
Hazard	What could happen	How to prevent it
Improper storage of extension cord.	Extension cord can come into contact with hot engine parts resulting in damage. Using a damaged extension cord can result in electrocution or death.	Remove extension cord from the generator and store separately away from generator.
Operation of generator in rain, wet, icy, or flooded conditions.	Water is an excellent conductor of electricity! Water which comes in contact with electrically charged components can transmit electricity to the frame and other surfaces, resulting in electrical shock to anyone contacting them.	Operate generator in a clean, dry, well ventilated area. Make sure hands are dry before touching unit.
Placing generator on or against highly conductive surface, such as a steel walkway or metal roof.	Accidental leakage of electrical current could charge conductive surfaces in contact with the generator.	Place generator on low conductivity surface such as a concrete slab. ALWAYS operate generator a minimum of 2 meters from any conductive surface.
Use of worn, damaged or ungrounded extension cords.	Contact with worn or damaged extension cords could result in electrocution. Use of ungrounded cordsets could prevent operation of circuit breakers and result in electrical shock.	Inspect extension cords before use and replace with new cord if required. Always use a cordset having a grounding wire with an appropriate grounding plug. DO NOT use an ungrounded plug.
Operation of unit when damaged, or with guards or panels removed.	Attempting to use the unit when it has been damaged, or when it is not functioning normally could result in fire or electrocution. Removal of guarding could expose electrically charged components and result in electrocution.	Do not operate generator with mechanical or electrical problem. Have unit repaired by an Authorized Service Centre. Do not operate generator with protective guarding removed.

Risk of fire		
Hazard	What could happen	How to prevent it
Attempting to fill the fuel tank while the engine is running.	Fuel and fuel vapours can become ignited by coming in contact with hot components such as the muffler, engine exhaust gases, or from an electrical spark.	Turn engine off and allow it to cool before adding fuel to the tank. Equip area of operation with a fire extinguisher certified to handle gasoline or fuel fires.
Sparks, fire, hot objects	Cigarettes, sparks, fires, or other hot objects can cause fuel or fuel vapours to ignite.	Add fuel to tank in well ventilated area. Make sure there are no sources of ignition near the generator.
Improper storage of fuel	Improperly stored fuel could lead to accidental ignition. Fuel improperly secured could get into the hands of children or other unqualified persons.	Store fuel in an approved container designed to hold fuel. Store container in secure location to prevent use by others.
Tampering with factory set engine speed settings.	Engine speed has been factory set to provide safe operation. Tampering with the engine speed adjustment could result in overheating of attachments and could cause a fire.	Never attempt to "speed-up" the engine to obtain more performance. Both the output voltage and frequency will be thrown out of standard by this practice, endangering attachments and the user.
Inadequate ventilation for generator	Materials placed against or near the generator or operating the generator in areas where the temperature exceeds 40° C ambient (such as storage rooms or garages) can interfere with its proper ventilation features causing overheating and possible ignition of the materials or buildings.	Operate generator in a clean, dry, well ventilated area. DO NOT OPERATE UNIT INDOORS OR IN ANY CONFINED AREA.

Overfilling the fuel tank – fuel spillage.	Spilled fuel and its vapours can become ignited from hot surfaces or sparks.	Use care in filling the tank to avoid spilling fuel. Make sure fuel cap is secured tightly and check engine for fuel leaks before starting engine. Move generator away from refuelling area or any spillage before starting engine. Allow for fuel expansion. Never refuel with the engine running.
---	--	---

Risk of injury and property damage when transporting generator		
Hazard	What could happen	How to prevent it
Fire, Inhalation, Damage to Vehicle Surfaces	Fuel or oil can leak or spill and could result in fire or breathing hazard, serious injury or death can result. Fuel or oil leaks can damage carpet, paint or other surfaces in vehicles or trailers.	The generator is equipped with a fuel tap, turn the lever of this valve to the off position before transporting to avoid fuel leaks. Transport fuel only in an approved fuel container. Always place generator on a protective mat when transporting to protect against damage to vehicle from leaks. Remove generator from vehicle immediately upon arrival at your destination.

Risk of breathing - inhalation hazard		
Hazard	What could happen	How to prevent it
Gasoline engines produce toxic carbon monoxide exhaust fumes.	Breathing exhaust fumes will cause serious injury or death.	Operate generator in clean, dry, well ventilated area. Never operate unit in enclosed areas such as garages, basements, storage, sheds, or in any location occupied by humans or animals. Keep children, pets and others away from area of operating unit.

Risk of unsafe operation		
Hazard	What could happen	How to prevent it
Operation of generator in careless manner.	All sources of energy include the potential for injury. Unsafe operation or maintenance of your generator could lead to serious injury or death to you or others.	<ul style="list-style-type: none"> • Review and understand all of the operating instructions and warnings in this manual. • Become familiar with the operation and controls of the generator. Know how to shut it off quickly. • Equip area of operation with a fire extinguisher certified to handle gasoline or fuel fires. • Keep children or others away from the generator at all times.
Operating generator while suspended	Generator will not operate properly and will cause damage to the generator and could cause serious injury or death to you or others.	Never operate generator while suspended or in an unlevel position. Always operate generator on a flat, level surface.

Risk of hot surfaces		
Hazard	What could happen	How to prevent it
Contact with hot engine and generator components.	Contact with hot surfaces, such as engines exhaust components, could result in serious burns.	During operation, touch only the control surfaces of the generator. Keep children away from the generator at all times. They may not be able to recognize the hazards of this product.

Risk of moving parts		
Hazard	What could happen	How to prevent it
Contact with moving parts can result in serious injury.	The generator contains parts which rotate at high speed during operation. These parts are covered by guarding to prevent injury.	Never operate generator with guarding or cover plates removed. Avoid wearing loose fitting clothing or jewellery which could be caught by moving parts.

Risk from lifting		
Hazard	What could happen	How to prevent it
Lifting a very heavy object.	Serious injury can result from attempting to lift too heavy an object.	When lifting, always keep the object you are lifting near the vertical axis of your body. DO NOT use you back to lift heavy loads. Both people should crouch down, grab the underside of unit and use your legs to carry the weight. Keep the object as near the centre of your body's gravity as possible. Avoid twisting your bodies when carrying the unit; instead, turn your whole body using your feet.

1. Do not operate in a hazardous location. Such areas include where there is a risk of explosion of petrol fumes, leaking gas or explosive dust.

2. Do not operate in a confined area. Exhaust gases, smoke or fumes could reach dangerous concentrations.

3. The output of this generator is potentially lethal. The generator should not be connected to a fixed electrical installation except by an appropriately licensed person.

4. Protect your generator. This generator is NOT WEATHERPROOF and should not be exposed to direct sunlight, high ambient temperature and damp, wet or high humidity conditions.

5. Do not smoke while refuelling. This is potentially dangerous as it may ignite the fuel and cause an explosion.

6. Take care not to spill fuel. When refuelling the generator ensure that the engine has been switched off. Prevent the spilling of fuel as this may also ignite with the hot engine. Never refuel whilst the engine running.

7. Be careful where you store the generator. Store the generator in a dry area away from inflammable liquids.

8. Keep your distance. The generator emits exhaust fumes. As a safety precaution do not stand close to the unit whilst it is in operation. Ensure bystanders also keep their distance.

9. Never fill fuel tank indoors. Never fill fuel tank when engine is running or hot. Do not smoke when filling fuel tank.

10. Engine speed has been factory set to provide safe operation. Tampering with the engine speed adjustment could result in overheating of attachments and could cause a fire. Never attempt to “speed-up” the engine to obtain more performance. Both the output voltage and frequency will be thrown out of standard by this practice, endangering attachments and the user.



WARNING!

You **MUST** unplug any load from the generator before starting and stopping to prevent permanent damage to any appliances.

Unpacking

Due to modern mass production techniques, it is unlikely that your POWERMAX Generator is faulty or that a part is missing. If you find anything wrong, do not operate the tool until the parts have been replaced or the fault has been rectified. Failure to do so could result in serious personal injury.

Know Your Product

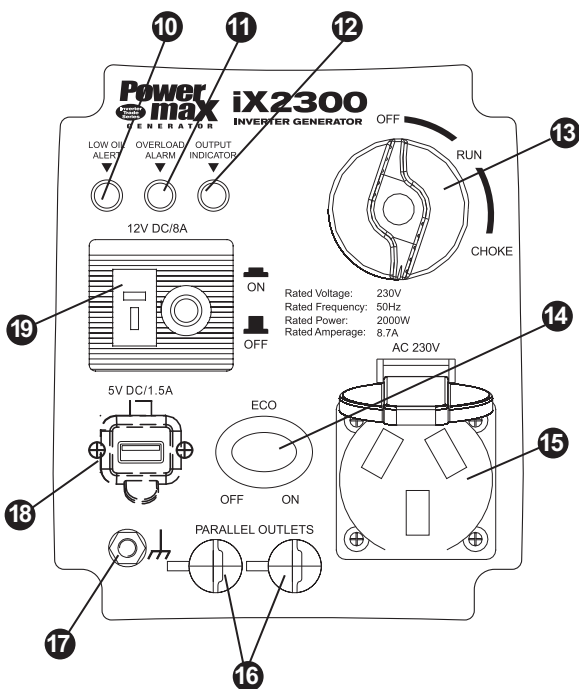
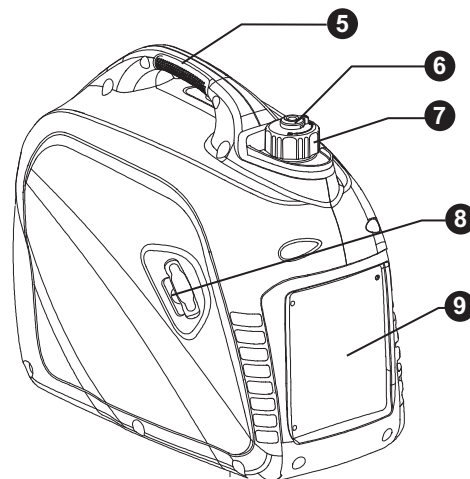
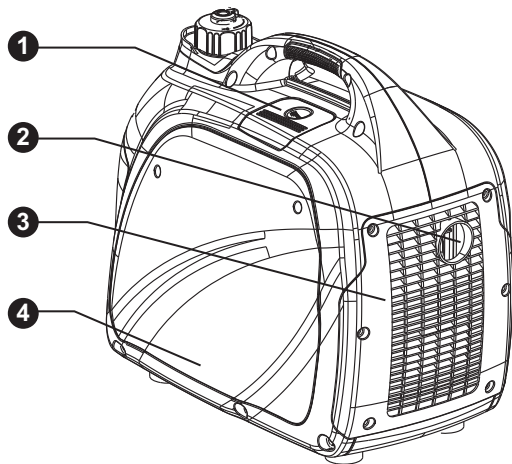

- 1 - Spark Plug Cover
- 2 - Spark Arrestor
- 3 - Muffler Cover
- 4 - Outer Casing (Side Panel)
- 5 - Handle (Grip)
- 6 - Air Vent
- 7 - Fuel Cap
- 8 - Recoil Starter

- 9 - Control Panel
- 10 - Oil Warning Light
- 11 - Overload Indicator Light
- 12 - AC Pilot Light
- 13 - 3 in 1 Start Switch (RUN / OFF and Choke)
- 14 - Economy Switch
- 15 - 230V AC Outlet
- 16 - Parallel Outlets
- 17 - Ground Terminal
- 18 - USB Outlet 5V DC / 1.5A
- 19 - 12V DC Port / 8A

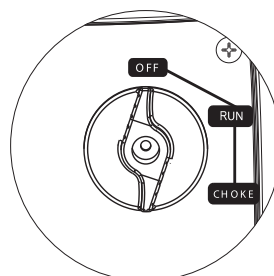

Control Panel Functions

ON/OFF Start Switch and Choke

Start Switch "OFF"

When the Start Switch is in the "OFF" position the fuel valve is switched off and the engine will not run.

Start Switch "CHOKE"

When the Start Switch is in the "CHOKE" position the fuel valve is switched on and the engine can be started.

Start Switch "RUN"

When the Start Switch is in the "RUN" position the fuel valve is switched on and the engine can run.

Note: The Choke is not required to start a warm engine

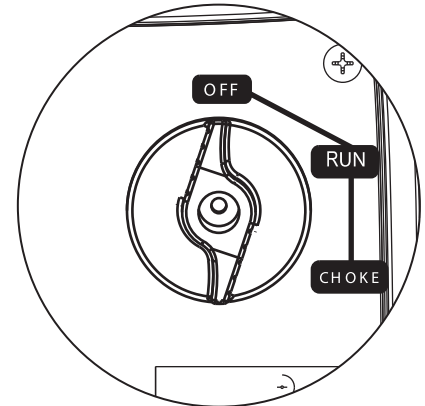

USB Outlet

The Generator offers convenient (5V DC 1.5A) USB outlet to allow charging of USB devices like tablets, MP3 players, GPS, digital cameras and other USB chargeable devices.

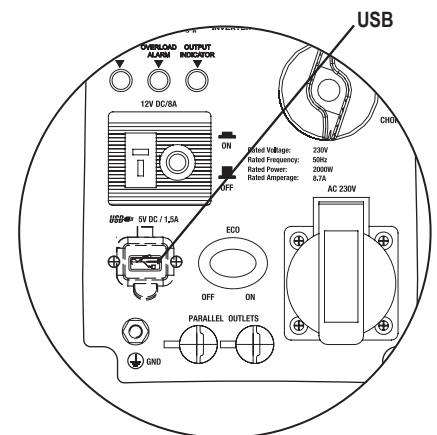

Oil Warning Indicator Light

When the oil falls below the minimum level, the oil warning indicator light comes on and the engine stops automatically. The engine will not start until the proper amount of oil is in the crank case.

Note: If the oil warning indicator light does not come on and the engine stalls, turn the Start Switch to "RUN" and pull the recoil starter.

Engine Overload Indicator Light

If the engine overload indicator light comes on, the generator's wattage / amperage capacity has been exceeded by connected electrical devices or by a power surge. When this occurs, the green AC Pilot Indicator Light will go off. The engine will continue to run, (but the red Engine Overload Indicator Light will stay on and power will no longer be supplied to connected electronic devices.)

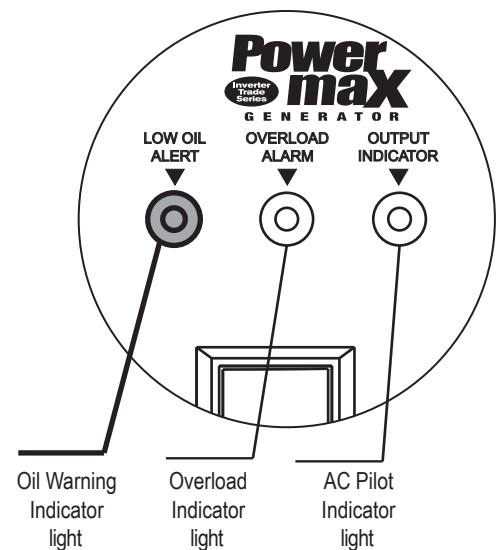

You will need to:

1. Disconnect any electronic devices then stop the engine.
2. Reduce the total wattage of connected electronic devices until it is within the generator's rated output.
3. Inspect the Air Inlet and Control Panel for any blockage. Remove blockage if found.
4. Restart Engine.

Note: The engine overload indicator light may turn on for a few seconds when attaching a load due to a power surge. This is normal.

AC Pilot Indicator Light

The green AC Pilot Indicator Light comes on when the engine starts and generates power.

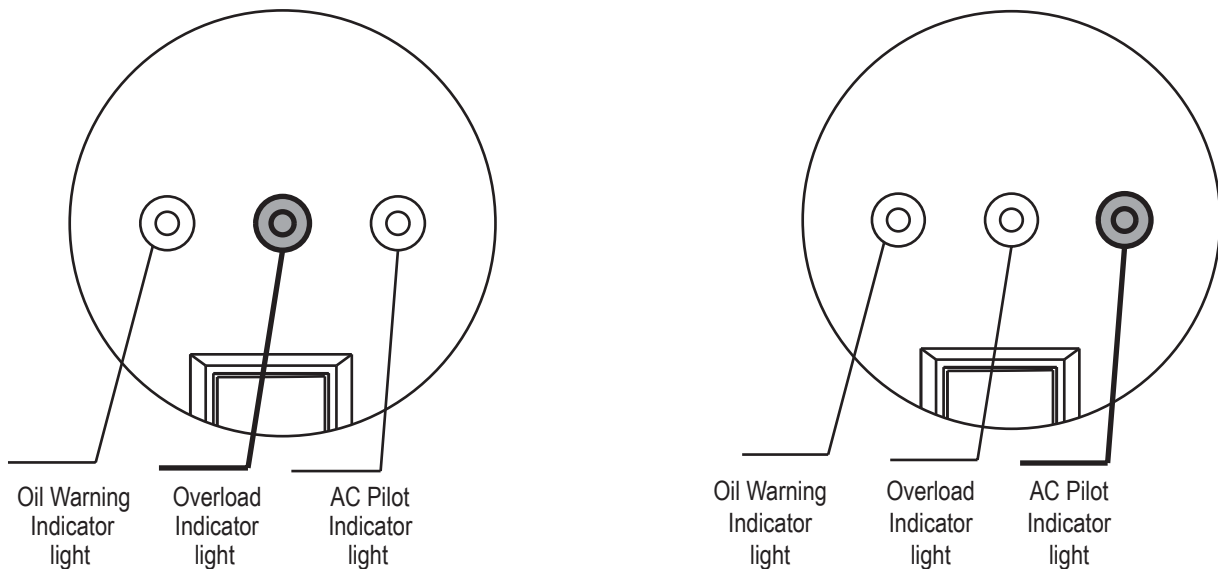

DC Circuit Breaker

When the DC Circuit Breaker is in the “ON” position, the generator is able to supply power to connected electronic devices. When the DC Circuit Breaker is in the “OFF” position, the generator will no longer supply power. The DC Circuit Breaker automatically turns “OFF” when connecting electronic devices to the generator that exceed the generator’s rated output. If the DC Circuit Breaker turns off, reduce the load of connected electronic devices until the load is within the specified rated output. To re-establish power, return the DC Circuit Breaker back to the “ON” position.

CAUTION!
If the DC Circuit Breaker turns off again, stop using the generator immediately and consult a qualified electrician or Powermax Service Agent.

Engine Economy Control

- When the Engine Economy switch is turned to the “ON” position, the economy control unit automatically determines the generator’s proper engine speed based on the connected electronic load. This results in superior fuel economy and reduces noise.
- When the Economy switch is turned to the “OFF” position, the engine runs at the rated speed of 4,100 r/min.

NOTE: The Economy switch must be turned to the “OFF” position when using electronic devices that require a large starting current, such as a compressor.

Parallel Outlets

Located just above the Ground Terminal, the generator’s Parallel Outlets enable a user to run two iX2300 generators simultaneously. This operation requires special cables. When operating parallel generators, the rated output is 3.0kVA and the rated current is 25A/120VAC. For cables and instructions consult a Powermax dealer for a parallel operation cable kit. See page 17 for more information.



WARNING!

Never connect generators that are different models.

- Only connect this generator to another Powermax iX2300 Generator
- Only use a parallel operation cable kit designed to work with this Generator.

Fuel Cap

Turn counterclockwise to remove the fuel cap.

Fuel Cap Air Vent

The fuel cap is equipped with an air vent to stop fuel from flowing to the carburetor. The Air Vent must be in the “ON” position to allow fuel to flow so that the engine can run. Turn the Air Vent to the “OFF” position to stop fuel flow.

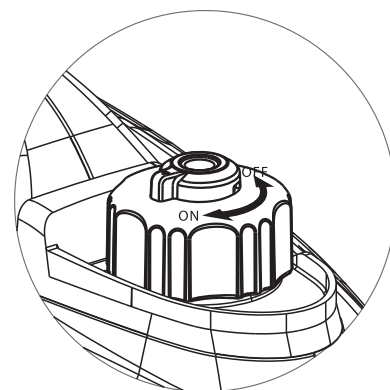

Ground Terminal

The generator’s ground terminal must always be used to connect the generator to a driven ground rod. Connect the ground terminal to the driven ground rod with a copper wire. The wire connects to the terminal between the lock washer and nut. Tighten the nut securely to ensure good connection. Grounding the generator protects you from electric shock that results from a build up of static electricity or undetected ground faults.

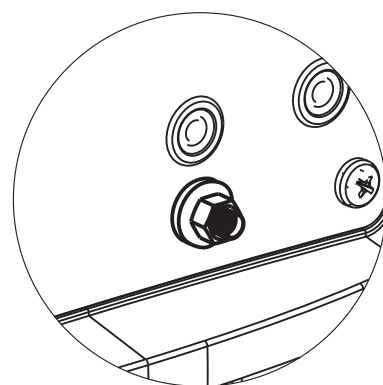

WARNING!

Generator must be properly grounded to prevent electrocution.

- Only operate generator on a level surface.
- Always connect the nut and ground terminal on the frame to an appropriate ground source.

Before Use

Connecting Generator to an Electrical System

- If connecting generator to a building's electrical system for standby power, you must use a qualified electrician to install a transfer switch. The power from the generator must be isolated from the circuit breaker or alternative power source. The connection must comply with all electrical codes and applicable laws.

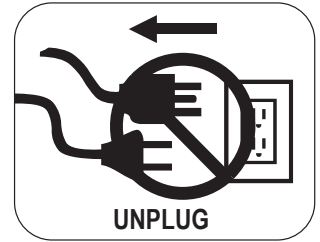

Never directly connect generator to a household power source.

WARNING!

This generator produces a very high voltage which could result in burn or electrocution causing serious injury or death.

- *Never handle the generator, electronic devices, or any cord while standing in water, while barefoot, or when hands or feet are wet.*
- *Always keep the generator dry. Never operate generator in rain or under wet conditions.*
- *Use a ground fault circuit interrupter (GFCI) in a damp or highly conductive area, such as metal decking or steel work.*
- *Never plug electronic devices into generator having frayed, worn, or bare wires. Never touch bare wires or make contact with receptacles.*
- *Never permit a child or unqualified person to operate generator. Keep children a minimum of 10 feet away from the generator at all times.*
- *If using the generator for back up power, notify the utility company .*
- *If connecting generator to a building's electrical system for sgtanby power, you must use a qualified electrician to install a transfer switch. Failure to isolate the generator from the power utility could result in serious injury or death to electric utility workers.*

Adding Fuel

1. Set generator on a clean and level surface in an area that is well ventilated.
2. Remove fuel cap.
3. Insert a funnel into the fuel tank and carefully pour gasoline into the tank until fuel level reaches about 1 ½ inches below the top of the neck. Be careful not to overfill the tank to provide space for fuel expansion.
4. Replace fuel cap and secure tightly.

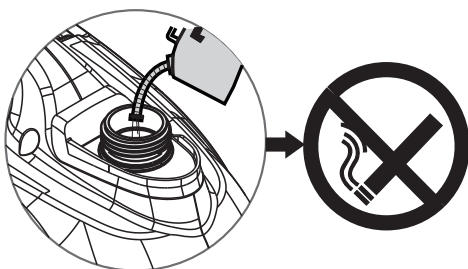

Do not smoke when adding fuel.

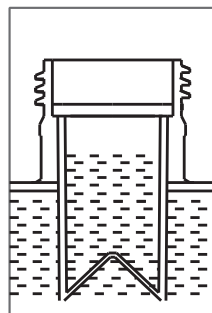

Do not overfill the fuel tank.
Provide space for fuel expansion.

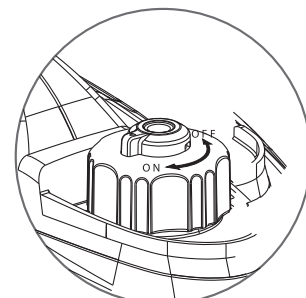

Turn cap counterclockwise
to remove.

Adding/Checking Engine Oil

- Place generator on a level surface.
- Remove screws and then remove the outer casing cover.
- Remove the crankcase dipstick.
- Insert a funnel into the crankcase dipstick hole and carefully add the specified amount of 4-Cycle engine oil (SAE 10W-30) to empty reservoir until or oil reaches the outer edge of the oil fill hole (crankcase dipstick hole).
- Be sure to replace dipstick and securely tighten before attempting to start the engine.
- To check oil, set generator on a level surface, wipe dipstick clean, then reinsert dipstick without re-threading.

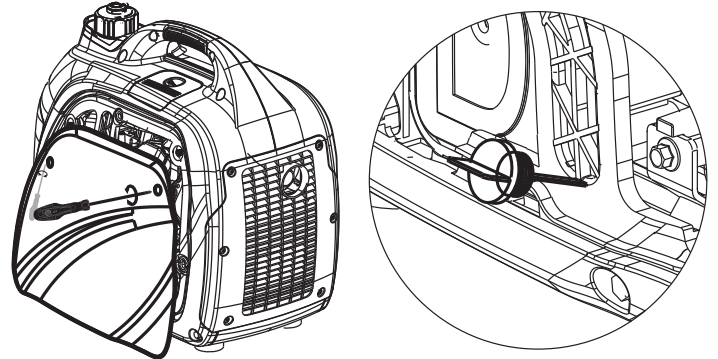

Recommended Oil: SAE 10W-30

Oil Capacity: 0.35L (11.8oz)



CAUTION!

Generator has been shipped without engine oil. You must add oil before operating this generator.

Always check oil level before each operation.

Grounding the Generator

To avoid electrocution, this generator must be properly grounded prior to use. For instructions see Control Panel Functions on page 11.

Standard Atmospheric Conditions

Ambient Temperature: 77°F (25°C)

Barometric Pressure: 100kPa

Relative Humidity: 30%

Generator output will vary due to changes in temperature, altitude, and humidity. If the temperature, humidity, or altitude are higher than standard atmospheric conditions, the generator's output will be reduced. The load attached to the generator must therefore be reduced.

How to Start Engine

- Place generator on a level surface. All electrical loads **MUST** be disconnected from generator.
- Turn the Economy switch to “OFF”
- Turn the fuel cap Air Vent to the “ON” position.
- Turn the 3 in 1 Start Switch to “CHOKE”
- Pull recoil handle (starter cord) slowly until resistance is felt, then pull rapidly.
- Let engine run for several seconds and then gradually, as engine warms up, turn the 3 in 1 Start Switch to the “RUN” position.

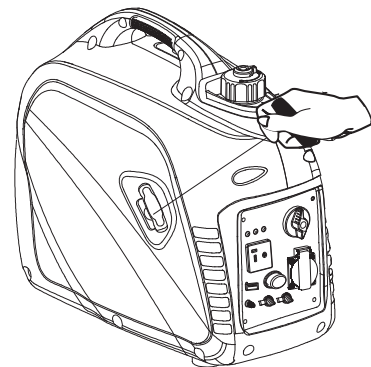
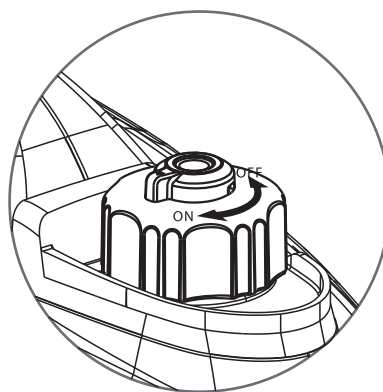
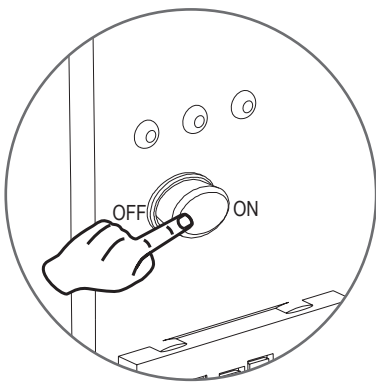

⚠ WARNING!
Pull cord recoils rapidly and pulls arm towards engine faster than you can let go which could result in injury.
To avoid recoil, pull starter cord slowly until resistance is felt, then pull rapidly.

To Use the Economy Switch

- Disconnect all electrical loads from generator.
- If ambient temperature is below 32°F (0°C) allow about 3 minutes for the engine to warm up.
- The Economy is in “ON” position, the unit returns to normal operation after the above warm up time.
- Economy switch must be turned to the “OFF” position when using electronic devices that require a large starting current, such as a compressor.

How to Stop Engine

- Turn the Economy switch to the “OFF” position.
- Disconnect any electronic device. All loads **MUST** be disconnect from the generator. Never start or stop the engine with electrical devices plugged in to the receptacles.
- Turn the 3 in 1 Start Switch to the “OFF” position.
- Turn the fuel cap Air Vent to the “OFF” position.

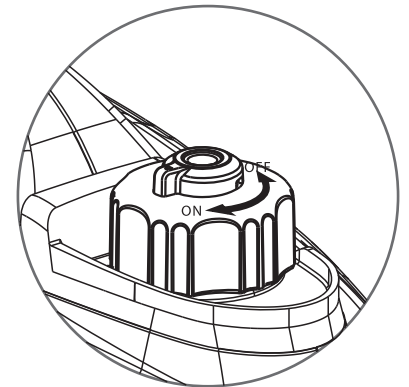
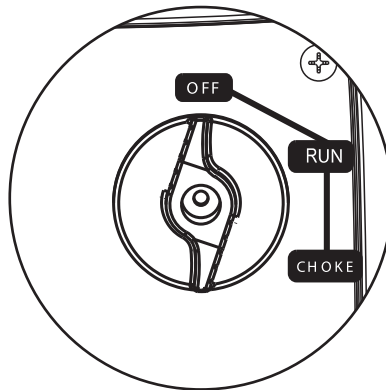
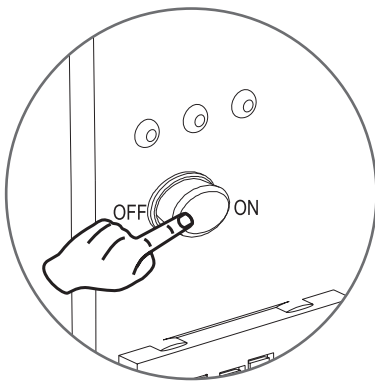

⚠ WARNING!
Never start or stop engine with electrical devices plugged in to the receptacles. Failure to do so could damage the generator and / or connected electrical devices.
*Always start the engine and let it stabilize before connecting any electronic devices.
Disconnect all electronic devices before stopping the engine.*

How to Attach Electronic Devices

1. Before starting generator
 - Make sure the generator is grounded (see page 11 for instructions).
 - Make sure the attached load is within the generator rated output and the receptacle’s rated current.
 - Make sure all electrical cords and receptacles are in good condition.
 - Make sure all electronic devices are turned “OFF” before plugging them into the generator.
2. Start engine
3. If the attached load is small, turn the Economy switch to the “ON” position. For a larger load, or if attaching multiple electronic devices turn the Economy switch to the “OFF” position.
4. Make sure the green AC pilot indicator light is on.
5. When engine has stabilized, plug in and turn on first load. It is strongly recommended to plug in devices with the largest output first and the smallest output last to help prevent overloading the generator.
6. Allow generator output to stabilize (engine and attached devices run evenly) before plugging in the next load.

Charging a 12 Volt Battery

This generator can be used to charge a 12 volt automotive or storage battery by taking the following steps:

Inspect fluid level of the battery cells. Add ONLY distilled water to any cell where fluid level is low. Never add tap water.

1. Use a wire brush to clean battery terminals if corroded.
2. Securely connect the red cable clamp to the positive (+) battery terminal.
3. Securely connect the black cable clamp to the negative (-) battery terminal.
4. Turn the Economy switch to the "OFF" position to start battery charging.
5. Battery is considered fully charged when the gravity of its fluid is between 1.26 and 1.28 when measured by a hydrometer.

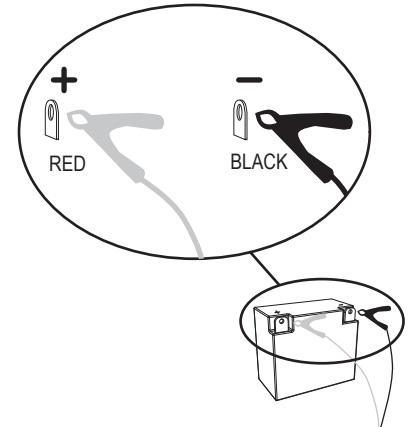

Note: It is strongly recommended to check the gravity level of the electrode at least once per hour with a hydrometer to prevent overcharging and to test the battery's condition. Be careful to follow the hydrometer manufacture's instruction.



WARNING!

Battery electrolyte is poisonous and dangerous.

- Do not disconnect battery clamps while charging. Batteries produce explosive gases. Disconnecting the battery clamps while charging could spark and ignite.
- Do not charge battery in an enclosed area.
- Never smoke while charging the battery or operating or fueling this generator.
- Battery electrolyte contains sulphuric acid. Avoid contact with skin, eyes, and clothing. Always wear eye protection when charging battery.
- If battery acid contacts skin, flush with water immediately. If it contacts eyes, flush with water for 15 minutes and get immediate medical attention. For internal ingestion, drink large quantities of water or milk, followed by milk of magnesia, beaten egg, or vegetable oil. Contact a medical physician immediately.

AC Parallel Operation

It is possible to connect two Powermax iX2300 generators to each other, using the optional parallel cable kit. These are available from your PowerMax Supplier and increase the available power output.

- Follow the instructions provided with the cable kit to connect the cables to the generators
- Make sure the Economy switch is in the same position on both generators.
- All electronic devices should be turned "OFF" and disconnected from generators prior to starting generator engines.
- Start generator engines. Make sure the green output indicator light comes on for each generator.
- When engines have stabilized, plug in electronic device to AC receptacle and turn on first load.
- Allow generator output to stabilize (engine and attached devices run evenly) before plugging in the next load.

Maximum Power in Parallel Operation: 4.0kVA

Rated Power in Parallel Operation: 3.0kVA

Limit operation time to 3 seconds for load requiring maximum output. For continuous operation, do not exceed the rated output.

It is strongly recommended to plug in devices with the largest output first and the smallest output last to help prevent overloading the generator.

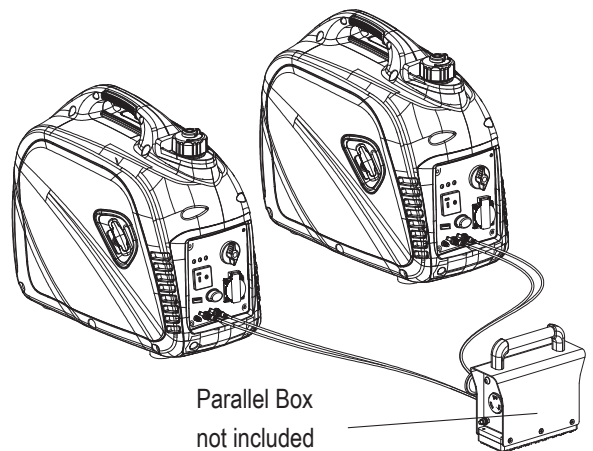

NOTE: Most electronic devices require power beyond its rated wattage to start. This additional power is referred to as surge watts and usually lasts between 2-3 seconds. When an electronic device is started, the red overload indicator may come on. This is normal. If the light stays on disconnect all electronic devices and stop the engine. Refer to "Engine Overload Indicator Light" on page 9.

WARNING!

Only connect electronic devices to the generator that are in good working order and do not exceed the rated power supply of the parallel generators or the desired receptacle.

- A faulty appliance or power cord can create an electric shock.
- Do not use electronic devices that have a damaged cord or plug.
- If an appliance begins to operate abnormally, becomes sluggish, or stalls, turn off and disconnect appliance immediately. The appliance may have a fault or its rated load capacity exceeds the power supply of the generator.
- To avoid damage to generator or electronic device, do not connect a load to the generator if its electrical rating exceeds that of the receptacle.

WARNING!

Never connect generators that are different models.

- Only connect this generator to another Powermax iX2300 Generator.
- Only use a Powermax approved parallel operation cable kit to connect generators.
- Do not run generators in parallel operation in excess of 30 minutes.
- The parallel cable must be removed if operating only one generator.
- Never disconnect or remove the parallel operation cable while generator is still running.

Approximate Wattage Requirements

IMPORTANT: Always check that the combined load of your appliances does not exceed the rated output of your generator. Always select a generator that has more capacity than your load requirements. The small amount extra you may invest to do this will be quickly recovered with the fuel saving and longer service life gained by not having to constantly run your generator at full load.

This chart lists average power requirements. Your particular tool or appliance may require more or less than the listed wattage.

* Where START wattage is the same as RUN wattage, this signifies no additional power is required for starting.

APPLIANCES / TOOLS	APPROX. RUN (W)	APPROX. START (W)	APPLIANCES / TOOLS	APPROX. RUN (W)	APPROX. START (W)
Microwave 750W	750	1200	Central Air Conditioner:		
Coffee Maker	1750	1750	10,000 BTU	1500	2200
Electric Clothes Drier	5750	5750	24,000 BTU	3800	5000
Washing Machine	1150	2300	32,000 BTU	5000	6500
Refrigerator	700	2200	Room Air Conditioner:		
Lights	100	100	10,000 BTU	1500	2200
Colour Television	350	350	Circular Saw 7 1/4"	1400	2300
Electric Frypan	1500	1500	Chainsaw 2HP	1100	2500
Dehumidifier	400	400	Portable Air Compressor	1200	3600
Computer - Desktop	700	700	Hand Drill 1/2"	600	600
VCR	50	50	Drill 1/2"	600	900
Dishwasher - Cool Dry	700	1400	Battery Charger 15 amp	500	700
- Hot Dry	1450	2000	Electric Welder 200 amp AC	9000	9000
Toaster - 2 Slice	1250	1250	Jigsaw	300	400
- 4 Slice	1600	1600	Electric Weed Trimmer	500	650
Freezer	2200	2500	Router	1000	1300
Hair Dryer	800-1700	800-1700	Belt Sander	1000	1300
Steam Iron	1800	1800	Table Saw 10"	1750	4250
Garage Door Opener - 1/4 HP	550	1100	Bench Grinder	1400	2450
- 1/3 HP	725	1400	Concrete Mixer 3.5c/f	1900	2500
Radio	200	200	Band Saw	1100	1350
Blender	375	500	Power Drill - Medium	1000	1200
Sump Pump 1/2 HP	1050	2150	- Heavy Duty	1500	1800
Well Pump 1/2 HP	1000	2100	Angle Grinder - 100mm	1000	1200
Household Water Pump	1200	2700	- 230mm	2400	2700

NOTE: Synchronous generators such as this model may not be suitable to power sensitive electronic equipment such as computers and other equipment with digital control circuitry. Operation of such equipment with this model generator may cause issues and/or permanent damage to the equipment. For powering sensitive electronic equipment, we recommend to use an inverter generator. Please contact your Powermax dealer for further details.

Maintenance

Regular maintenance will extend the life of this generator and improve its performance. The warranty does not cover items that result from operator negligence, misuse, or abuse. To receive full value from the warranty, operator must maintain the generator as instructed in this manual, including proper storage.

 **WARNING!** Before inspecting or servicing this machine, make sure the engine is off and no parts are moving. Disconnect the spark plug wire and move it away from the spark plug.

 **CAUTION!** If you are unsure of how to perform a maintenance task, have the unit serviced by a Powermax dealer

 **CAUTION!** Only use Powermax replacement parts.

Pre-Operation Steps

Before starting the engine, perform the following pre-operation steps:

- Check the level of the engine oil and the fuel tank level. Check for any leakage.
- Check fuel hose for cracks or damage. Replace if necessary.
- Make sure the air filter is clean.
- Remove any debris that has collected on the generator and around the muffler and controls. Use a vacuum cleaner to pick up loose debris. If dirt is caked on, use a soft bristle brush.
- Inspect the work area for hazards.

After Each Use

Follow the following procedure after each use:

- Shut off engine.
- Store unit in a clean and dry area.

Maintenance Schedule

After First 5 Hours	Change Oil.
After 8 Hours or Daily	Clean Debris.
	Check Engine Oil Level.
6 Months (100 hr Use)	Check and Clean Air Filter Element. (Service more often under wet or dusty conditions.)
	Change Engine Oil. (Service more often under dirty or dusty conditions.)
	Check Muffler Screen. Replace if necessary.
	Service Spark Plug.
	Inspect Muffler and Spark Arrester.
12 Months (300 hr Use)	Clean Fuel Filter. Replace if necessary.
	Check Crankcase Breather Hose for cracks or damage. Replace if necessary.
	De-carbonize cylinder head. See dealer.
	Check and adjust Valve Clearance. See dealer.
	Check all Fittings and Fasteners. See dealer.

Checking Spark Plug

- Remove cap. Then remove spark plug cap.
- Disconnect the spark plug wire from the spark plug.
- Before removing the spark plug, clean the area around its base to prevent debris from entering the engine.
- Insert a spark plug socket wrench through the opening on the outside of the cover. Turn the wrench counterclockwise.
- Check for discoloration and clean carbon deposits off the electrode with a wire brush.
- Check the electrode gap and slowly adjust to 0.6 - 0.7mm (0.024-0.028 in) if necessary.
- Reinstall spark plug and tighten to Torque 20.0Nm (14.8ft-lb).
- If spark plug is worn replace only with an equivalent replacement part. Spark plug should be replaced annually.
- Reconnect spark plug wire.
- Replace spark plug cap, then replace cap.

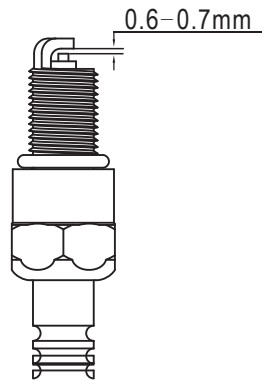
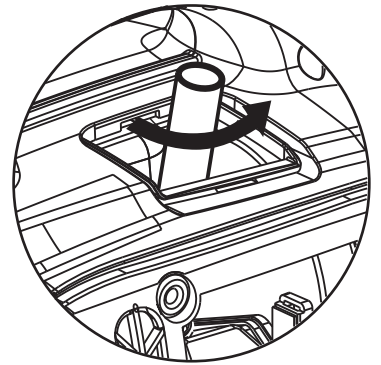
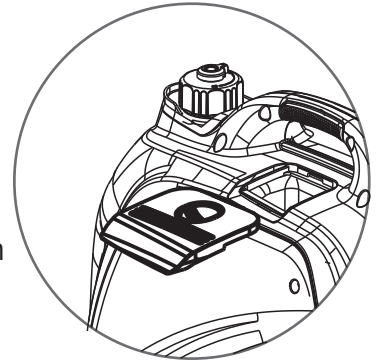

Standard Spark Plug: E6TC/E6RTC/BPR6HS

Spark Plug Gap: 0.6 - 0.7mm (0.024-0.028 in)

Spark Plug Torque: 20.0Nm (14.8ft-lb)

Carburetor Adjustment

The carburetor is low emission and is equipped with a non-adjustable idle mixture valve. If adjustment is needed contact an authorized dealer.

Oil Recommendations

- Do not use special additives.
- Outdoor temperatures determine the proper oil viscosity for the engine. Use this chart to select the best viscosity for the outdoor temperature range expected.

NOTE: * Below 40°F (4 °C) the use of SAE 30 will result in hard starting.

** Above 80°F (27 °C) the use of 10W-30 may cause increased oil consumption.

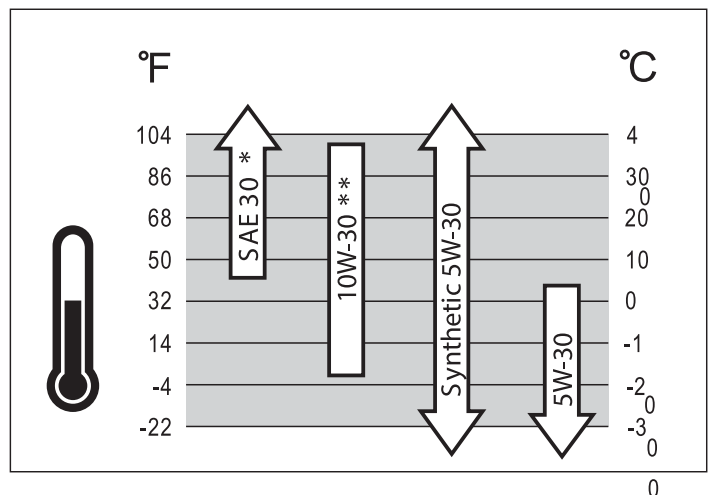

Check oil level more frequently

Changing Oil

1. Place generator on a level surface.
2. Run the generator for several minutes until the engine is warm. Turn off generator.
3. Remove screws, then remove outer casing side cover.
4. Remove the crankcase dipstick.
5. Place an oil pan underneath the engine. Tilt generator to collect used oil. Allow oil to drain completely.
6. Return generator to a level surface.
7. Carefully add 4-Cycle engine oil (SAE 10W-30) to empty reservoir until oil reaches the outer edge of the oil fill hole.
8. Use a clean rag to wipe up any spilled oil.
9. Replace crankcase dipstick.
10. Reinstall outer casing side cover and tighten screws.

Recommended Engine Oil: SAE 10W-30

Recommended Engine Oil Grade: API Service SE type or higher quality of engine oil.

Engine Oil Quantity: 0.35L (0.924 US gal)

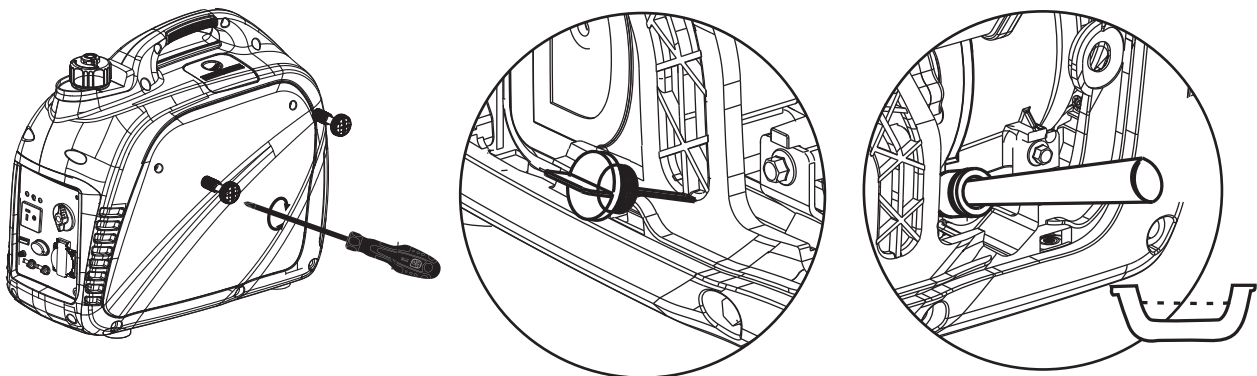

CAUTION!

Do not tilt generator when adding oil. This could result in overfilling which could damage the engine.



CAUTION!

Make sure no foreign matter enters the crankcase

Air Filter

A dirty air filter will reduce the life span of the engine, make it difficult to start the engine, and reduce the unit's performance. Replace with new filter annually.

- To clean, remove the screws then remove outer casing.
- Remove the screws then remove air filter cover.
- Remove the foam element.
- Wash the foam element in solvent and let dry.
- Pour a small amount of oil on the foam element then squeeze out, but do not wring out, excess oil. Foam element should be damp, but not dripping.
- Reinsert the foam element into the air filter case.

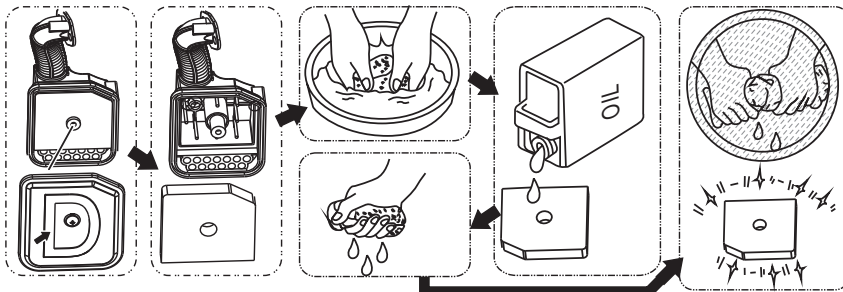
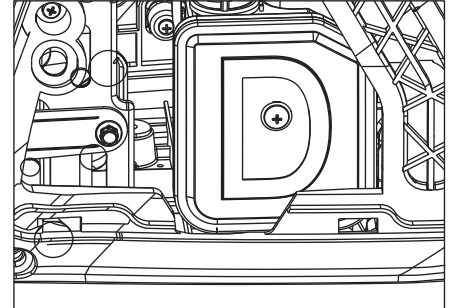

CAUTION!
Don't run generator without reinstalling foam element or excessive piston and cylinder wear may result.

Checking Muffler and Spark Arrester

1. Inspect muffler for cracks, corrosion, or other damage.
2. Remove screws, then remove the muffler cover as shown.
3. Loosen bolt, then remove muffler cap, muffler screen, and spark arrester.
4. Check the muffler screen and spark arrester for carbon deposits. Remove carbon deposits with a wire brush.
5. Check the muffler screen and spark arrester for damage. If damaged replace with Powermax replacement parts specifically designed for this unit.
6. Install the spark arrester. Align the spark arrester projection with the hole in the muffler pipe.
7. Install the muffler screen and muffler cap.
8. Install the outer casing and tighten the screws.

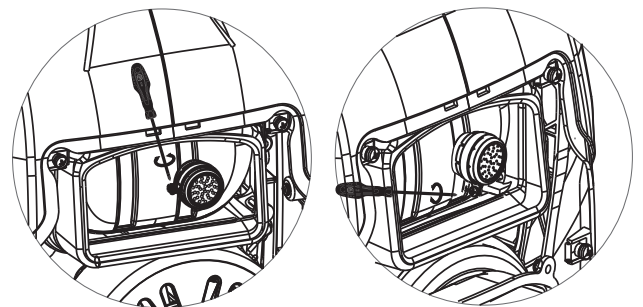
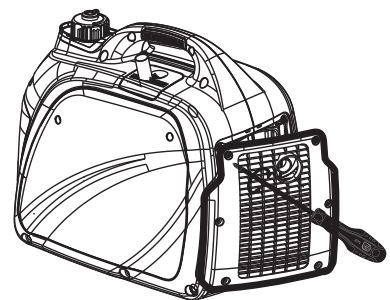

WARNING!
Avoid contacting hot areas of this unit.
Use caution around the muffler, cylinder, and other engine parts as they can be extremely hot.
Allow hot components to cool before touching.

Cleaning the Fuel Tank Filter

1. Remove fuel cap and filter.
2. Clean filter with gasoline.
3. Wipe the filter with a clean rag.
4. Install filter.
5. Install fuel cap.

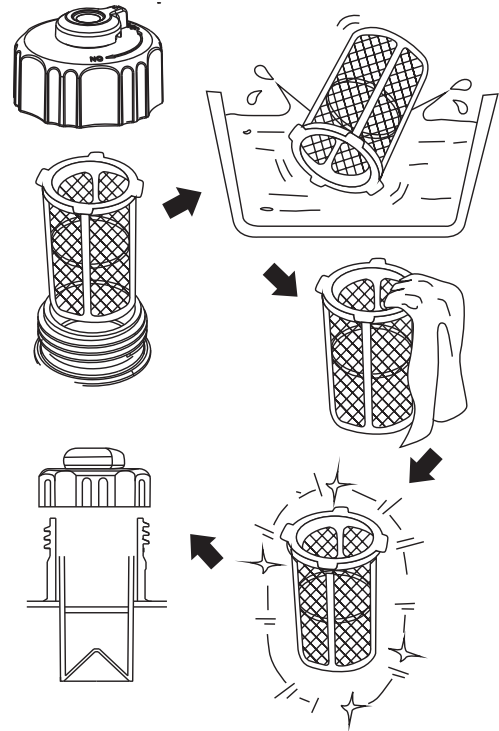

Cleaning the Fuel Filter

1. Remove screws, remove outer casing, and drain fuel.
2. Lift and hold onto the clamp, then remove hose from tank.
3. Take out fuel filter.
4. Clean filter with gasoline.
5. Wipe the filter with a clean rag and return filter to tank.
6. Install hose and clamp.
7. Open fuel valve. Inspect for leakage.
8. Install outer casing and tighten screws.

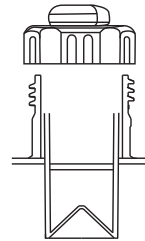

Storage and Transportation

Transporting

When transporting the generator, turn the 3 in 1 Start Switch (ON/OFF and Choke) OFF. Keep the generator level to prevent fuel spillage. Fuel vapor or spilled fuel may ignite.

- Remove any debris that has collected on the generator and around the muffler and control panel. Use a brush or vacuum to remove loose dirt.
- Inspect air cooling slots. Remove any debris if obstructed.
- For short-term storage, start the generator once every 7 days.
- For semi-long term storage, add fuel stabilizer to prevent stale fuel from causing acid and gum deposits in the fuel system and carburetor.
- For long-term storage, drain the fuel.
- Store indoors to prevent freezing and use a protective cover to protect from dust.
- The generator must be shipped, run, and stored in the upright position as seen in this image.

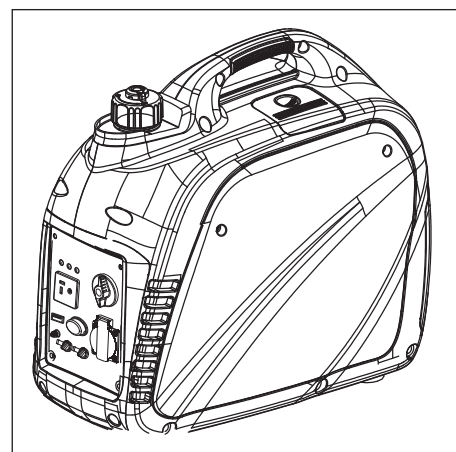

WARNING!

Contact with a hot engine or exhaust system can cause serious burns or fires.
Let the engine cool before transporting or storing the generator.



CAUTION!

Take care not to drop or strike the generator when transporting. Do not place heavy objects on the generator.

Maintaining the Engine Before Long Term Storage

1. Remove the spark plug and pour about 1 teaspoon of 10W-30 engine oil into the spark plug hole.
2. Reinstall the spark plug. With the 3 in 1 switch in the "OFF" position pull the recoil starter cord several times to coat the cylinder walls with oil.
3. Slowly pull the recoil starter until you feel the engine build compression (when you feel resistance).
4. Leave the engine in this state as this will prevent any corrosion on the cylinder walls if stored for a long period of time.

Draining the Fuel

- Turn the 3 in 1 switch to the "OFF" position.
- Remove fuel cap and fuel tank filter.
- Use a siphon to transfer gasoline from generator into a gasoline approved container.
- Wipe up any spilled fuel with a clean rag.
- Start generator engine and let it run until it stops and all remaining fuel is consumed. Do not connect electronic devices to generator during this process.
- Remove outer casing screws, then remove outer casing.
- Drain fuel from carburetor by loosening the drain screw on the carburetor float chamber.
- Turn the 3 in 1 switch to "OFF"
- Tighten the drain screw.
- Install the outer casing and tighten screws.
- When the engine has completely cooled down, turn the Fuel Cap Air Vent to the "OFF" position.

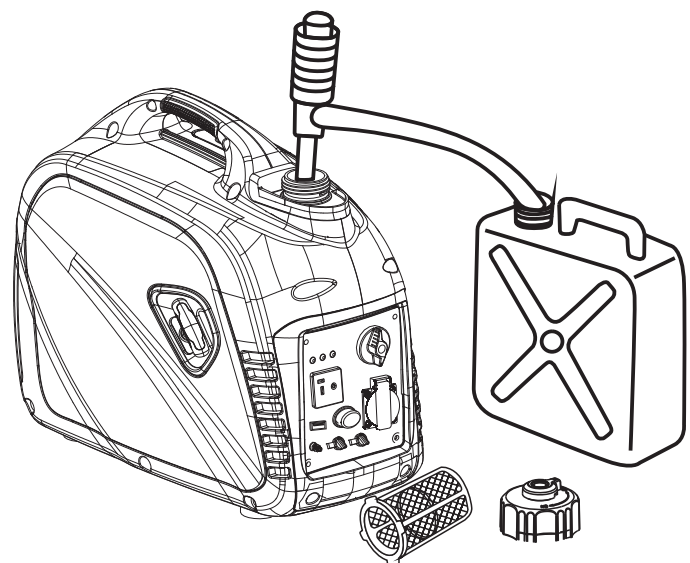
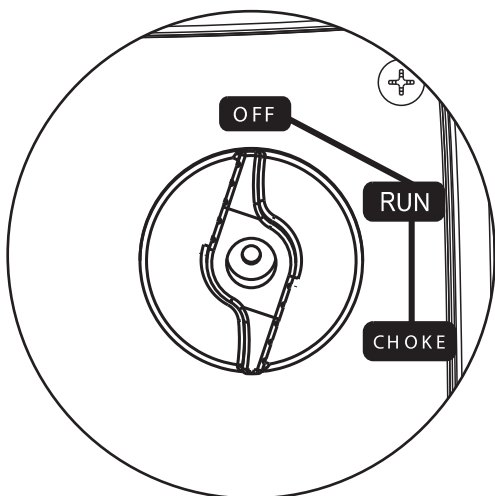

Troubleshooting

Problem	Cause	Solution
Generator is running, but does not supply power.	<ol style="list-style-type: none"> 1. DC circuit breaker is "OFF" 2. Green AC pilot light indicator is off. 3. Poor connection 4. Defective cord set 5. Connected device is faulty 6. Fault in generator 	<ol style="list-style-type: none"> 1. Turn DC Circuit Breaker "ON" 2. Stop engine and restart. 3. Check and repair 4. Check and repair 5. Connect a device that is working properly 6. Contact service department
Engine runs good without load but bogs down when loads are connected	<ol style="list-style-type: none"> 1. Short circuit in connected device 2. Generator is overloaded 3. Clogged fuel filter 4. Engine speed is too slow 5. Short circuit in generator 	<ol style="list-style-type: none"> 1. Disconnect device 2. See pg 9 about overloading generator 3. Clean or replace fuel filter 4. Contact service department 5. Contact service department
Engine will not start, shuts down during operation, or starts and runs rough.	<ol style="list-style-type: none"> 1. 3 in 1 switch set to "OFF" 2. Dirty air filter 3. Clogged fuel filter 4. Out of fuel or stale fuel 5. Spark plug wire disconnected from spark plug 6. Bad spark plug 7. Water in fuel 8. Overchoking 9. Low oil level 10. Engine has flooded 11. Faulty ignition 	<ol style="list-style-type: none"> 1. Turn switch to "CHOKE" then pull recoil starter. 2. Clean or replace air filter 3. Clean or replace fuel filter 4. Replace fuel 5. Reconnect spark plug wire 6. Clean or replace spark plug 7. Drain fuel tank and replace fuel 8. Turn off choke 9. Add oil level. 10. Wait 5 minutes and re crank engine 11. Contact Powermax dealer
Engine lacks power	<ol style="list-style-type: none"> 1. Generator is overloaded 2. Clogged fuel filter 3. Dirty air filter 4. Engine needs servicing 	<ol style="list-style-type: none"> 1. See pg 9 about overloading 2. Clean or replace fuel filter 3. Replace air filter 4. Contact service department
Engine "hunts" or falters	<ol style="list-style-type: none"> 1. Choke was removed too soon 2. Clogged fuel filter 3. Carburetor is running too rich or too lean 	<ol style="list-style-type: none"> 1. Move to choke until engine runs evenly 2. Clean or replace fuel filter 3. Contact service department

Wiring Diagram

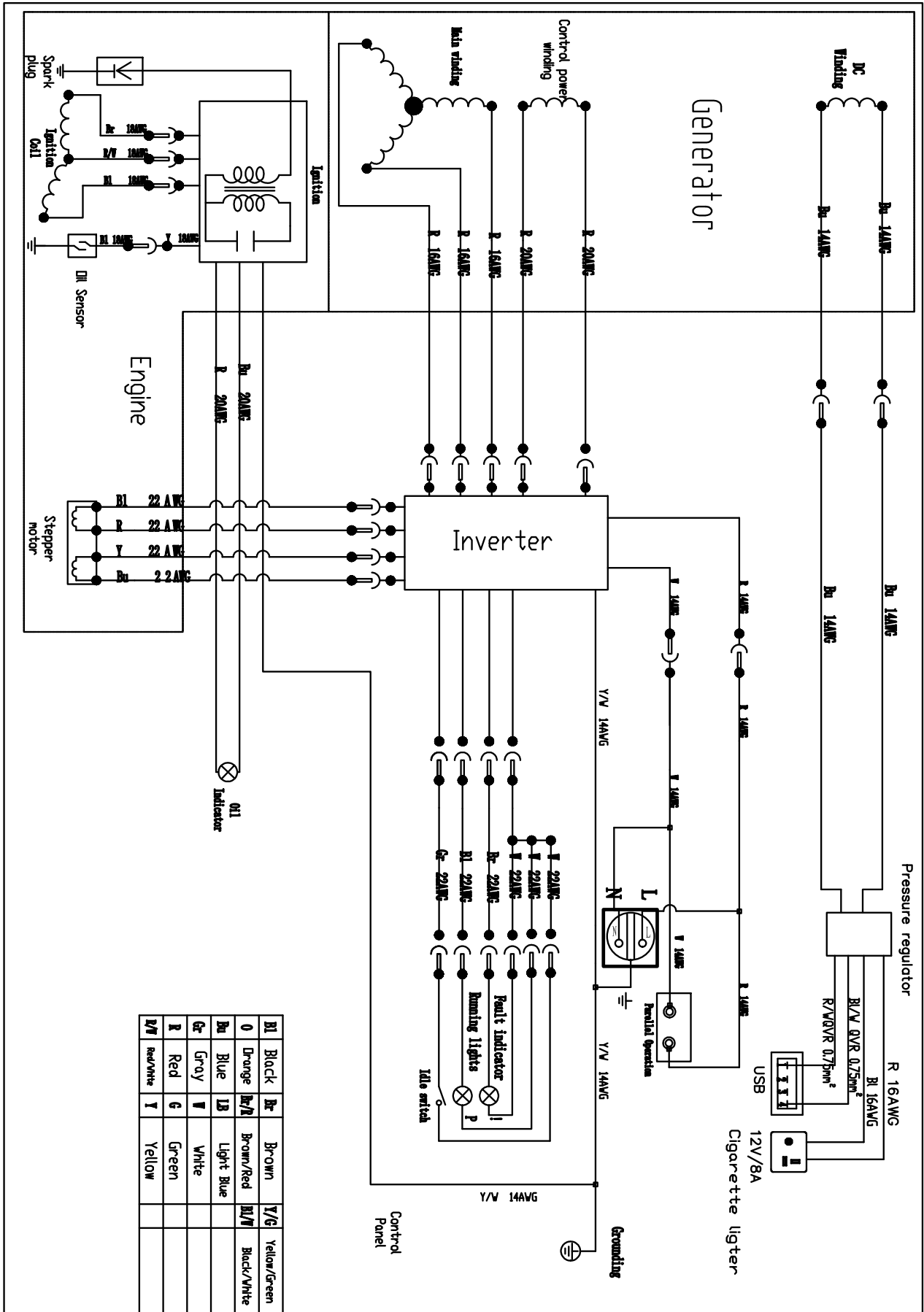

Notes

Notes

Warranty

As part of an on-going commitment to excellence in product support, Euroquip offers a comprehensive product warranty program.

1. THIS WARRANTY:

The benefits provided to the consumer in this warranty are in addition to other rights and remedies of a consumer under the New Zealand Consumer Guarantees Act 1993 and any other laws in relation to the products to which this warranty relates. This warranty:

- Covers the product against faulty materials or workmanship; and
- Covers the replacement of parts, the repair labour used, a refund of the price of the product or replacement of the machine, or other compensation for the remainder of the warranty period.

This product warranty is only applicable to the original purchaser of the machine and only purchases made from Euroquip Authorized Retailers.

2) WARRANTY PERIODS:

Domestic/Commercial: 12 Months

Or

1000 hours of operation – whichever occurs first.

Domestic Warranty applies to domestic use of the product: Personal, residential, or household use only. Commercial Warranty applies to commercial or business use of the product: All uses other than domestic use, including use for income-producing (including farming) or rental purposes.

*These Powermax Warranty periods are for products that are:

- Serviced by a Powermax Dealer in accordance with the Powermax service schedule, using genuine parts and the correct grade of oil (proof required)
- Meeting all other warranty requirements

NOTE: These warranty conditions apply to New Zealand only.

Euroquip warrants each new Powermax machine free from defect in material and workmanship under normal use and routine servicing, for the warranty periods specified. Conditional to the limitations and exclusions list below. The warranty period begins when the product is purchased by the end user. Warranty is not transferrable and is only claimable by the original purchaser.

Proof of purchase documentation with product serial number must be provided. If it has been lost and Euroquip does not have a record of the purchaser's details, the warranty period shall be calculated from the appropriate dealer wholesale sale date.

The purchaser must keep a record of all service and maintenance history as proof of servicing history. This may be requested when assessing any future warranty claims. The decision that an issue with a product qualifies as a warranty claim is made at the sole jurisdiction of Euroquip.

No costs incurred will be considered under warranty if repairs or maintenance are carried out by any party other than a Euroquip Approved Service Agent, unless with prior consent in writing from Euroquip.

It is the full responsibility of the purchaser to deliver the product under warranty to the nearest relevant service agent or product reseller. Warranty does not cover transportation costs including call outs, mileage and freight costs.

Customers are responsible for the care and cleaning of their product prior to sending it to our service centre. Any product being sent us must be thoroughly cleaned. Depending on what the product has come into contact with, it could pose an Occupational/ Work Health and Safety risk for our staff and or/service agents to inspect, repair or service a product that has come into contact with a hazardous substance. If we are asked to inspect, repair or service a product that has come into contact with a hazardous substance such as chemicals, asbestos or silica dust, we may not be able to inspect, service or repair the product. If this is the case, we will inform the purchaser and the product will be returned.

If a product is repaired under warranty, parts and labour required for the repair will be supplied at no charge. All defective parts replaced under warranty become property of Euroquip. Consumable items such as, but not limited to, oils, coolants, filter and spark plugs shall be the responsibility of the owner. Warranty assessment and repair will be scheduled and executed according to the normal work flow at the service location and depending on the availability of suitable replacement parts.

This warranty policy is an additional benefit and does not supersede the legal rights of any customer, reseller or service agent.

Should any issue be found to be a combination of a warranty failure and a non-warranty issue such as incorrect charging techniques, the repair cost component to rectify and repair the non-warranty failure is the **customer's** full responsibility.

3) EXCLUSIONS:

- Warranty does not cover parts that are subject to wear and tear from usage and/or damage which results from neglect of periodic maintenance.
- Evidence must be provided that the product has been maintained and serviced suitably for a claim to be considered under warranty.
- Batteries supplied with your product are warranted against defect for 3 months and does not include lack of charge due to non-use. Consumable items such as, but not limited to, oils, coolants, filters, spark plugs and batteries shall be the responsibility of the purchaser.
- Failure caused by incorrect operation of the product as specified in the manual either intentionally or by error.
- Lack of proper care and maintenance of the product.
- Any damage which results from unavoidable natural disasters, fire, collision, theft, etc.
- Any normal wear or deterioration, such as that of sliding or rotating parts caused under normal operating conditions.
- Any damage that results from misuse or use beyond the imitations of the products intended purpose (such as overloading or use under abnormal conditions).
- External circumstances such as product deterioration or corrosion due to environmental conditions like heat, cold, salt spray, sand or due to the passage of time
- Normal phenomena such as noise, vibration or oil seepage which are considered by Euroquip as not affecting the quality, function or performance of the product.
- Any damage due to improper storage or transport.
- Consumable replacement items: Spark plugs, contact points, shear pins, fuel strainers, oil filter elements, air cleaner elements, brake shoes or pads, clutch components, fuses, motor brushes, gaskets, tube or hoses, belts, cutting blades, light bulbs, serviceable bearings. Petroleum and others fluids: Oil, grease, battery electrolyte, and radiator coolant. Other items specified by Euroquip.
- Periodical maintenance items such as cleaning, inspection and adjustments.
- Contaminated fuel
- Modifications or installations of other products to the product
- Damage that results from the use of non-genuine parts, lubricant or fluid not approved by Euroquip
- Any repair and/or adjustment to correct improper or poor quality work previously performed.
- Attempted repair/ service by a party other than an Approved Service Agent, or any repair undertaken prior to approval of warranty by Euroquip is not covered under warranty.
- Warranty does not cover pre delivery service and adjustment, or failure that may occur as a result of lack of/ incorrect pre delivery service and adjustment. Warranty does not cover any incidental, indirect or consequential loss, damage, personal injury, or expense that may result from any defect, failure, malfunction, or misuse of a product.
- Any product that is found to have come into contact with hazardous substances such as chemicals, asbestos or silica dust and NOT been industrially cleaned prior to servicing.

4) HOW TO CLAIM WARRANTY:

In the event you are faced with a manufacturing fault with your Powermax product, you can claim a repair or part replacement under warranty if the following conditions are fulfilled:

- The problem is related to production quality or specifications of the machine
- The machine is within the warranty period outlined in schedule
- The issue does not fall within the warranty exclusions listed

If the criteria above is met, and you would like to request a warranty, then please go online to <https://www.euroquip.co.nz/Service-Request-End-User> and log your warranty claim.



Congratulations on your new POWERMAX product. We are proud to have you as our customer and will strive to provide you with the best service and reliability in the industry. This product is backed by our extensive warranty. To locate your nearest distributor or service agency call **0800 387 678**, or email us at **customerservice@euroquip.co.nz**.